



MOBILITY 22G

5-in-1 cellular and Wi-Fi antenna system with GPS antenna

Features

- 5-in-1 cellular and Wi-Fi antenna system with GPS antenna
- 2x2 Cellular frequencies:
600-6000 MHz
- 2x2 Wi-Fi frequencies:
2400-2500 MHz & 5000-6000 MHz
- Durable and UV-stable housing
- Black or white color options
- IP68 rated



Overview

Antenna elements	2x LTE/5G, 2x WIFI, 1x GPS
Cellular frequencies	1.2dBi: 617-960MHz 5.7dBi: 1710-2700MHz 5.6dBi: 3400-4200MHz 6.0dBi: 5000-6000MHz
Cellular bands	LTE bands B1 to B86 (except B31, B72, B73, B87, B88), 5G bands n1 to n99
Wi-Fi frequency bands	4.8dBi: 2400-2500MHz 7.4dBi: 5000-6000MHz
GPS frequency bands	1.6dBi, LNA 28dB: 1561-1602MHz
IP rating	IP68
Dimensions	(Height) 1.42" / 36mm (spigot not included) (Diameter) 5.12" / 130mm
Coax cable type	CFD-200 (4G/5G, Wi-Fi) RG-174 (GPS)
Connector Type	SMA male (4G/5G, GPS), RP-SMA male (Wi-Fi)

Description

The Peplink Mobility 22G is a 5 in 1 antenna built for mobile applications. It supports 2x2 cellular MIMO for high bandwidth and solid reliability, dual-band (2.4GHz & 5GHz) Wi-Fi and GPS. It is also 5G ready and supports a wide range of global cellular frequencies. The GPS antenna is equipped with high gain LNA, making it ideal for location tracking.

The Mobility 22G has a solid housing made of UV stable plastic materials. Two color options are available (black and white) to fit different deployments. For easier installation, the antenna comes with different cable length options.

Applications

- Public Safety and mission critical connectivity
- Mobile healthcare
- Transportation Connectivity

Mobility 22G

Contact Us

sales@peplink.com

Find a Peplink Certified Partner

<https://www.peplink.com/peplink-certified-partners/>



Specification

Cellular

Antenna elements	2 elements
Cellular frequencies	1.2dBi: 617-960MHz 5.7dBi: 1710-2700MHz 5.6dBi: 3400-4200MHz 6.0dBi: 5000-6000MHz
Cellular bands	LTE bands B1 to B86 (except B31, B72, B73, B87, B88), 5G bands n1 to n99
VSWR	< 2.5 over 85% of the band
Feed power handling	10W
Input impedance	50 Ω
Polarisation	Linear
Ground plane	Not required #

Wi-Fi

Antenna elements	2 elements
Peak gain	4.8dBi: 2400-2500MHz 7.4dBi: 5000-6000MHz
VSWR	< 2.5
Feed power handling:	10W
Input impedance:	50 Ω
Polarisation:	Linear

GPS

Frequency range	1561-1602 MHz
Peak gain	0.5dBi@1575MHz 1.6dBi@1602MHz
VSWR	< 2 dB
Output return loss	10dB max
Gain: LNA	28 ±3dB
Noise figure	1.5dB max at 3.3V
Operating Voltage	3.3V
Power consumption	8.5 ±2.5mA at 3.3V

Cable

Type	CFD-200
Loss	0.33 dB/m @ 900 MHz 0.49 dB/m @ 2000 MHz 0.55 dB/m @ 2500 MHz 0.87 dB/m @ 5800 MHz
Diameter	0.2" / 5.0mm
Jacket	Half matt PVC, UV resistant
Termination	SMA male and RP-SMA male
Type	RG-174
Loss	3.4 dB/m @ 1000 MHz 4.9 dB/m @ 1800 MHz
Diameter	0.1" / 2.7mm
Jacket	Half matt PVC, UV resistant
Termination	SMA male

Mobility 22G

Mounting

Supported types	Panel, wall, pole
Mounting hole	1 11/16" / 43mm
Max panel thickness	19/32" / 15mm

Mechanical

Product dimensions	(Height) 1.42" / 36mm (spigot not included) (Diameter) 5.12" / 130mm
Packaged dimensions	8.90" x 8.46" x 4.29" / 226 x 215 x 109mm
Radome material	UV stable PC+ABS

Package contents

Antenna	Mobility 22G
Mounting	Mounting bracket Wall/pole mount Double sided 3M adhesive pad Diameter: 5.08" / 129mm Thickness: 0.08" / 2mm

Environmental, compliance

Cable flammability	UL 758 (VW-1)
Compliance	RoHS, REACH & WHEE
Enclosure flammability	UL 94 HB
IP rating	IP68
Operating temperature	-40° - 176°F / -40° - 80°C
Storage temperature	-40° - 176°F / -40° - 80°C
Salt Spray	MIL-STD 810F/ASTM 8117
UV resistance rating	UL 746C (F1, long-term UV exposure)
Wind Survival	220 km/h

#All measurements stated in this document were obtained without a ground plane.



Ordering information

Mobility 22G

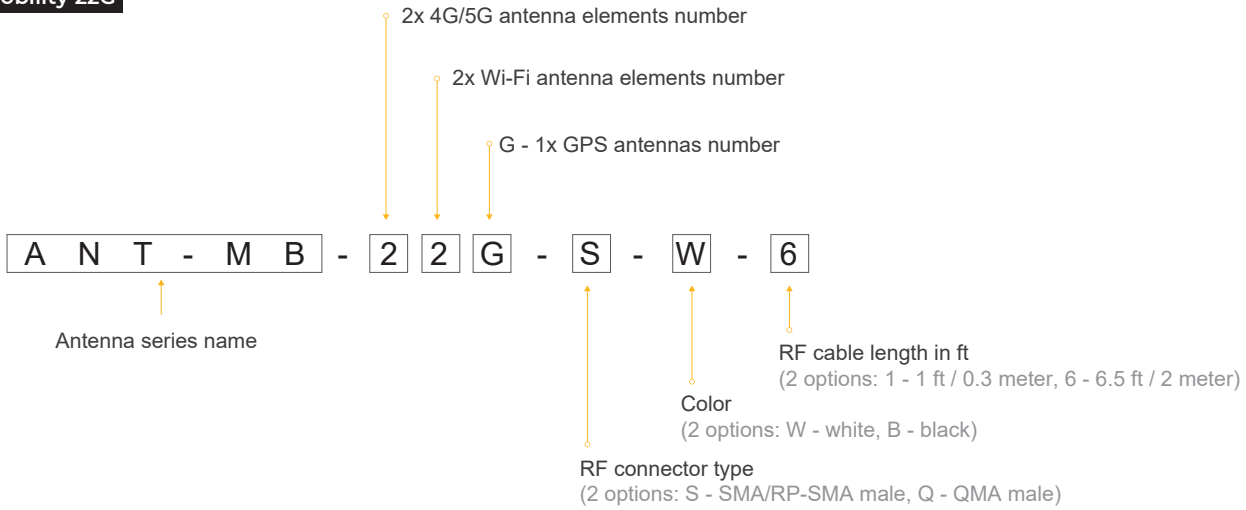

Product Code	Description
ANT-MB-22G-S-W-6	2xLTE, 2x Wi-Fi, 1xGPS 600-6000MHz, IP68, SMA male (Cellular, GPS), RP-SMA male (Wi-Fi), White, 6.5ft / 2m
ANT-MB-22G-S-B-6	2xLTE, 2x Wi-Fi, 1xGPS 600-6000MHz, IP68, SMA male (Cellular, GPS), RP-SMA male (Wi-Fi), Black, 6.5ft / 2m
ANT-MB-22G-Q-W-1	2xLTE, 2x Wi-Fi, 1xGPS 600-6000MHz, IP68, QMA male, White, 1 ft / 0.3m
ANT-MB-22G-Q-B-1	2xLTE, 2x Wi-Fi, 1xGPS 600-6000MHz, IP68, QMA male, Black, 1 ft / 0.3m

Extension cable

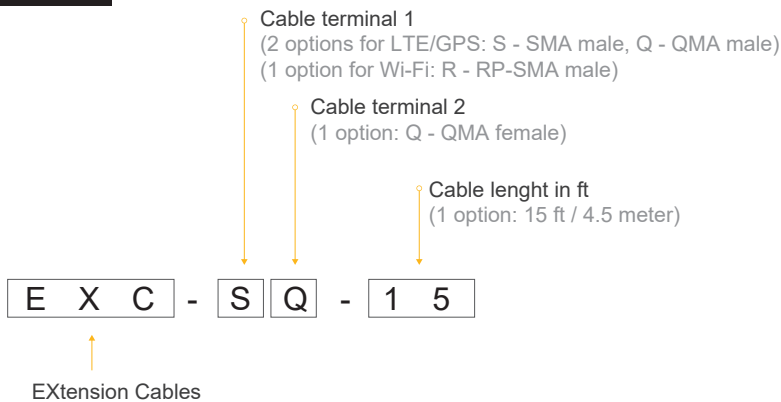

LTE/GPS elements

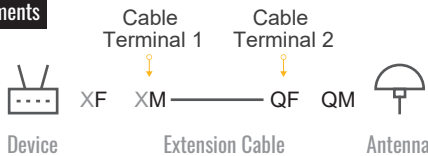

Wi-Fi elements

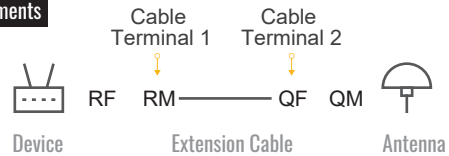

Product Code	Element type	Description
EXC-SQ-15	LTE/GPS elements	Extension coax cable, SMA male to QMA female connector, 15ft / 4.5m
EXC-QQ-15	LTE/GPS elements	Extension coax cable, QMA male to QMA female connector, 15ft / 4.5m
EXC-RQ-15	Wi-Fi elements	Extension coax cable, RP-SMA male to QMA female connector, 15ft / 4.5m

Mobility 22G

Technical drawing

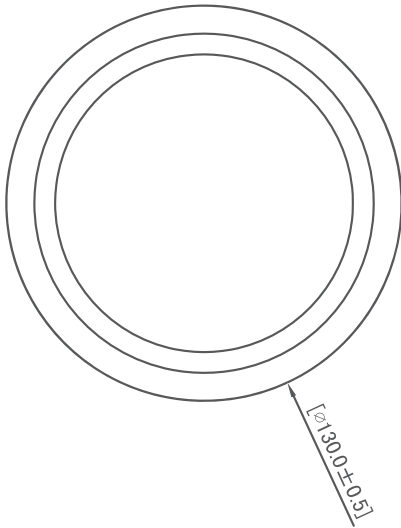

Mobility 22G

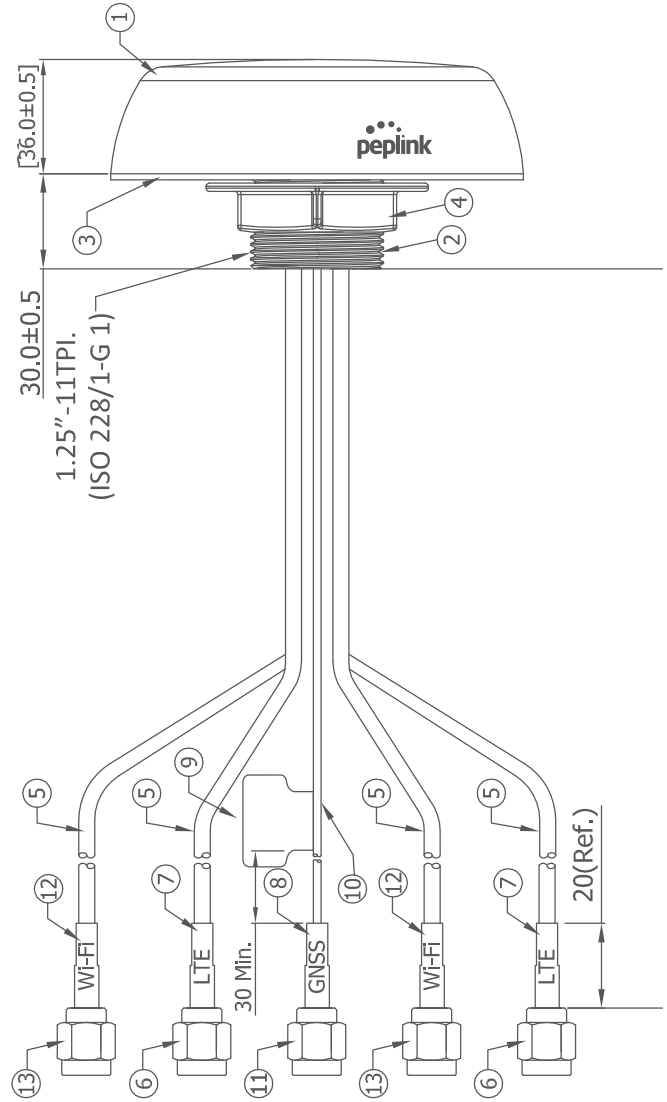

Index

No.	Description	Qty
1	Antenna top cover (PC+ABS)	1
2	Antenna bottom cover (PC+ABS)	1
3	Double sided 3M adhesive pad	1
4	Hexagon NUT (PC+ABS)	1
5	Cable CFD-200 (4G/5G, Wi-Fi)	4
6	LTE/5G antenna connector	2
7	LTE/5G cable marking	2
8	GPS cable marking	1
9	Label	1
10	Cable RG-174 (GPS)	1
11	GPS antenna connector	1
12	Wi-Fi cable marking	2
13	Wi-Fi antenna connector	2

Antenna VSWR

LTE/5G Antenna VSWR

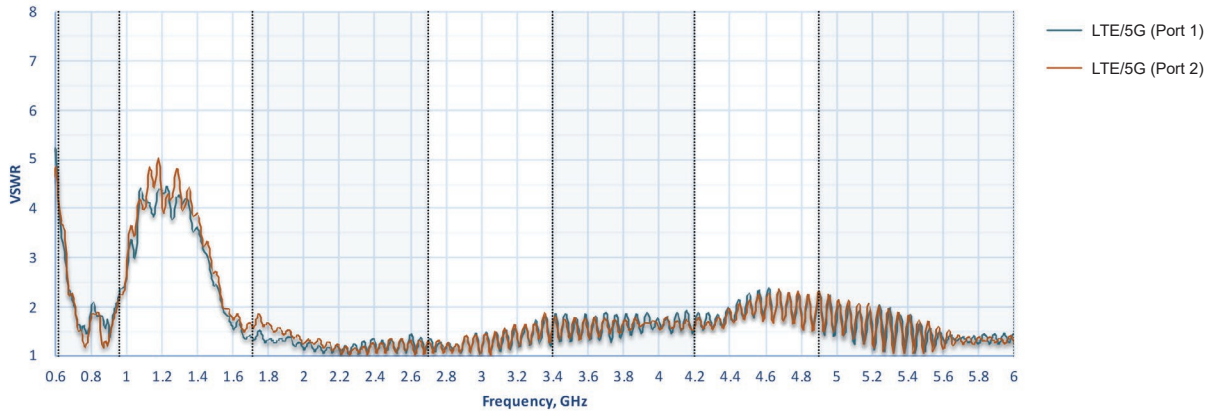

Wi-Fi Antenna VSMR

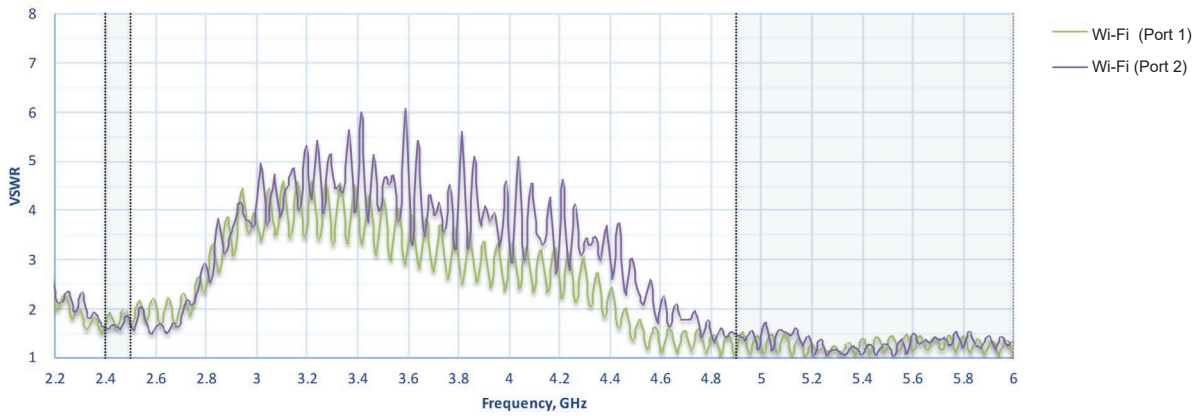

Mobility 22G

Antenna Gain

LTE/5G Antenna Gain

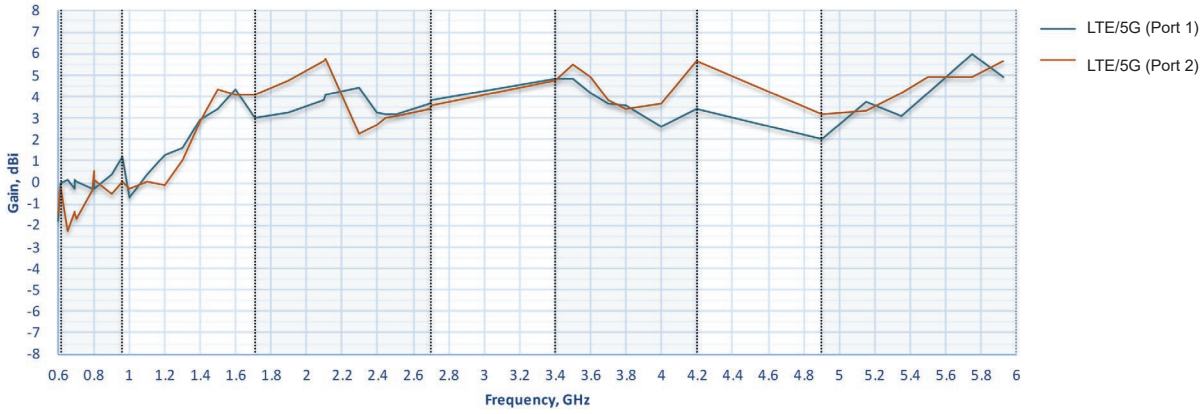

Wi-Fi Antenna Gain

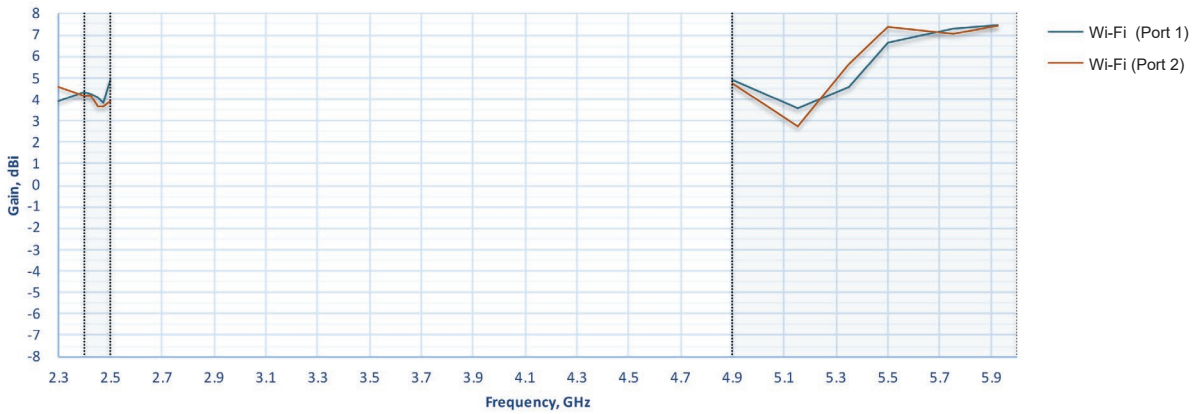

Mobility 22G

Antenna Efficiency

LTE/5G Antenna Efficiency

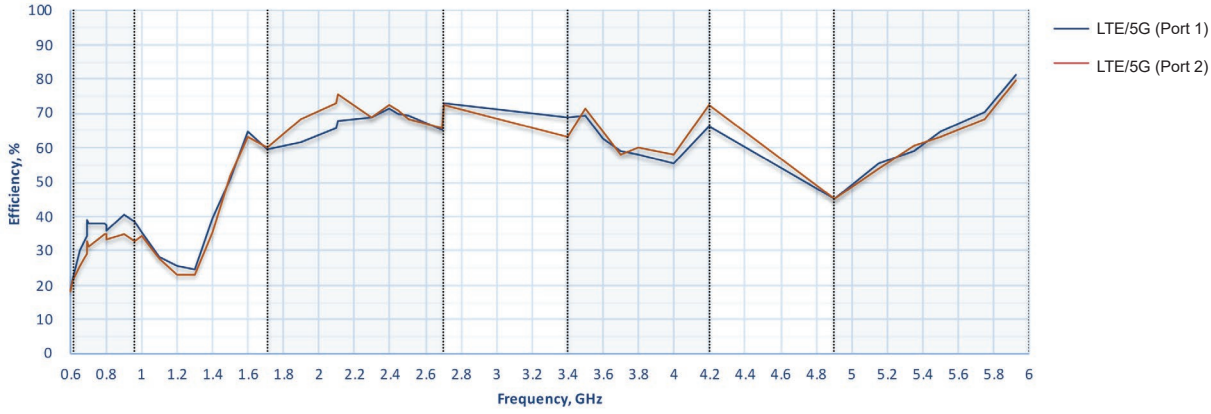

Wi-Fi Antenna Efficiency

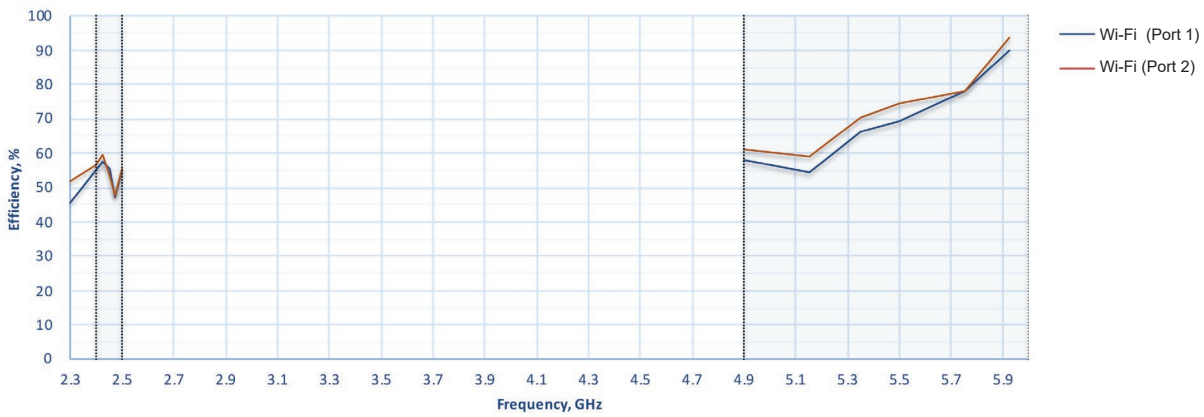

Antenna Isolation

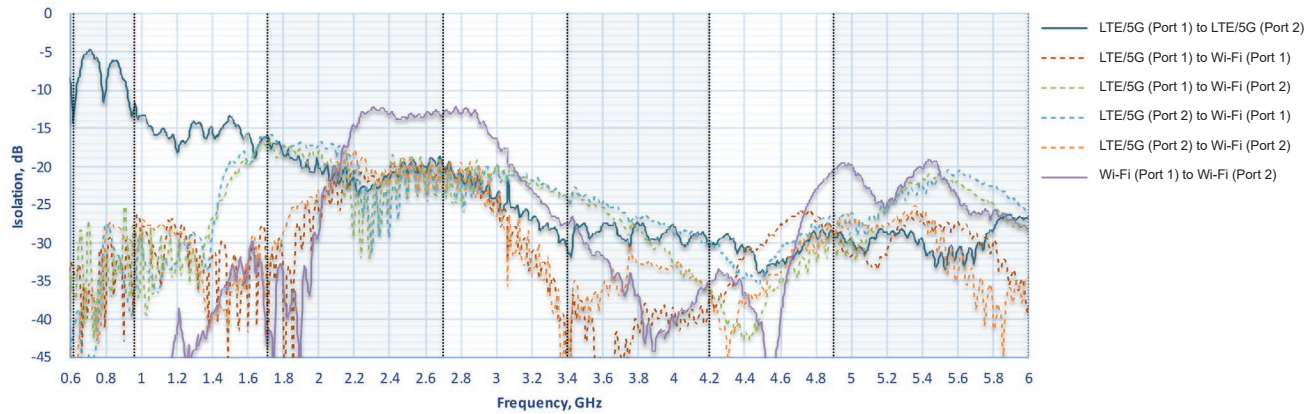

LTE/5G Antenna Radiation patterns (Azimuth)

617-960 MHz

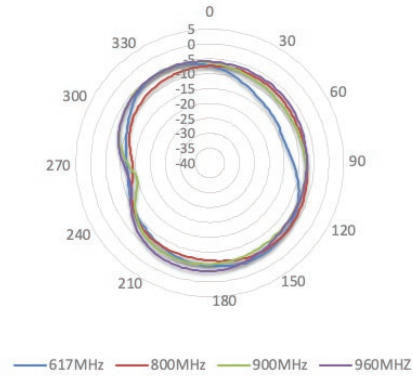

1710-2100MHz

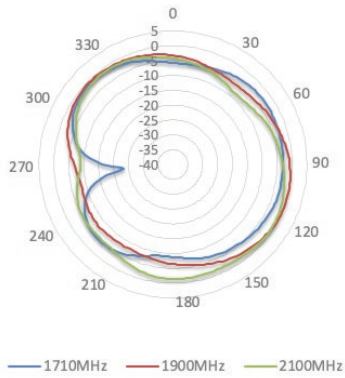

2300-2700 MHz

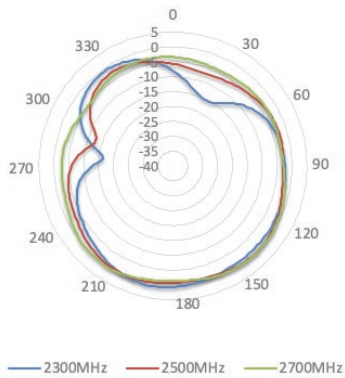

LTE/5G Antenna Radiation patterns (Azimuth)

3400-3800 MHz

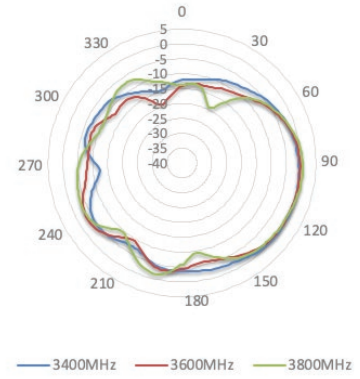

4200-5150 MHz

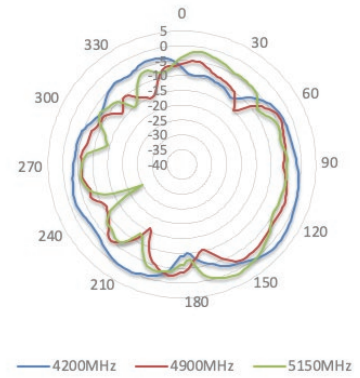

5350-5930 MHz

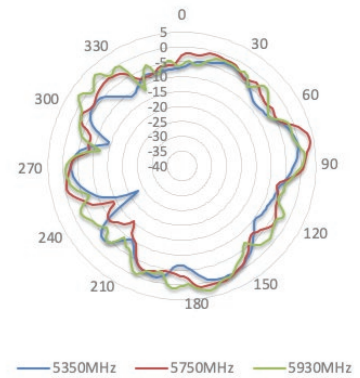

Mobility 22G

Wi-Fi Antenna Radiation patterns (Azimuth)

2400-2500 MHz

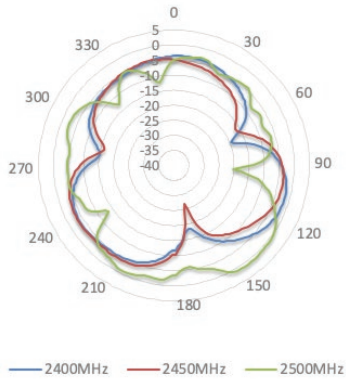

4900-5350 MHz

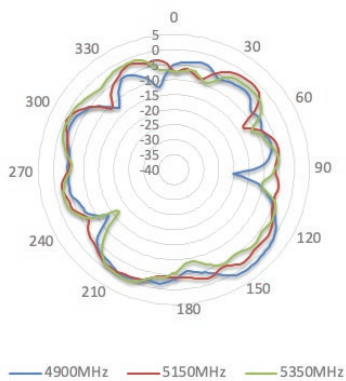

5500-5950 MHz

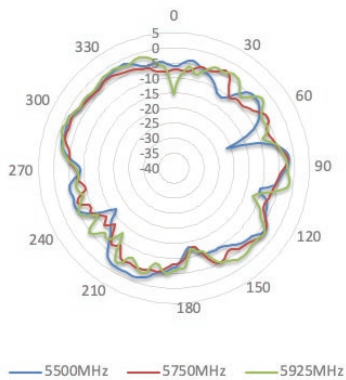

LTE/5G Antenna Radiation patterns (Elevation 1)

617-960 MHz

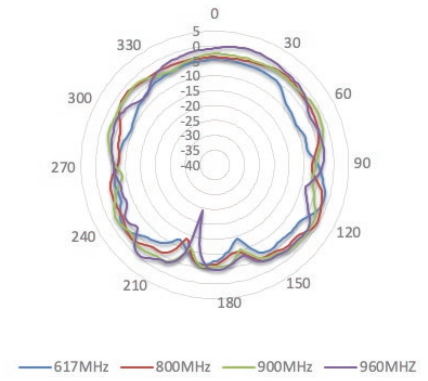

1710-2100MHz

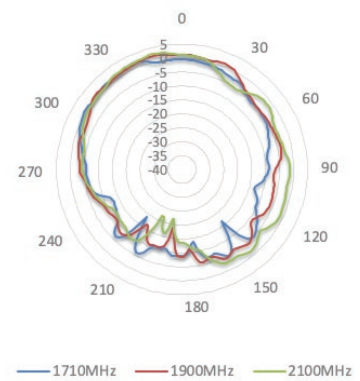

2300-2700 MHz

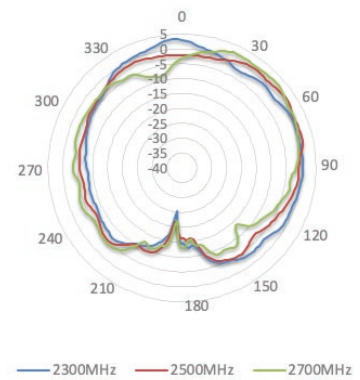

Mobility 22G

LTE/5G Antenna Radiation patterns (Elevation 1)

3400-3800 MHz

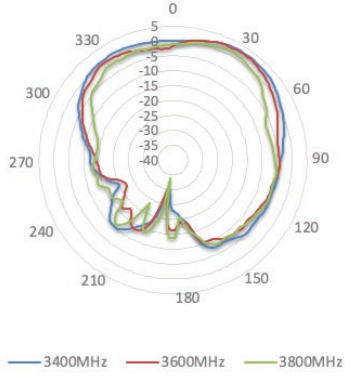

4200-5150 MHz

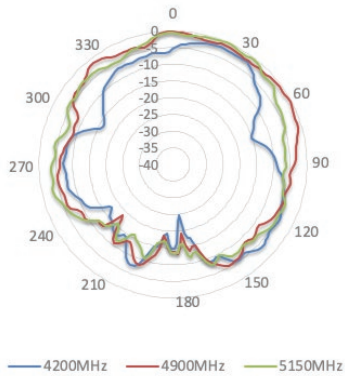

5350-5930 MHz

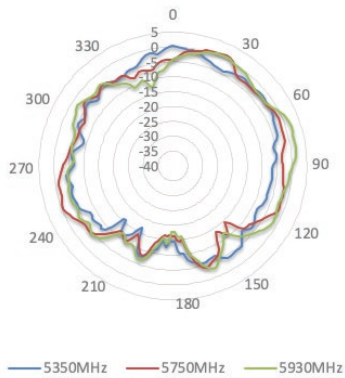

Wi-Fi Antenna Radiation patterns (Elevation 1)

2400-2500 MHz

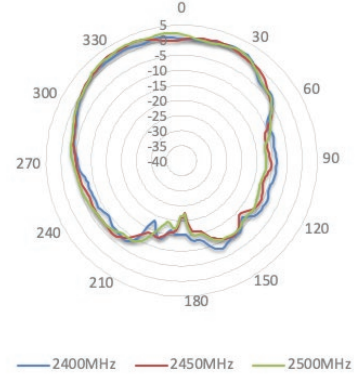

4900-5350 MHz

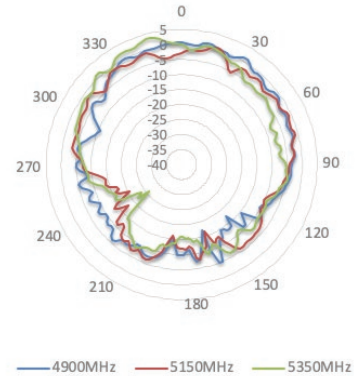

5550-5950 MHz

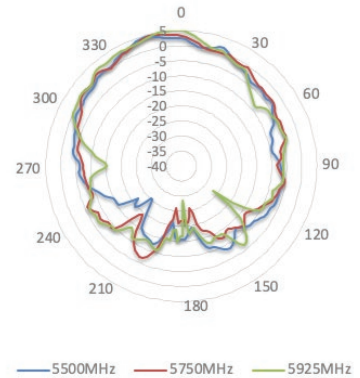

Mobility 22G

LTE/5G Antenna Radiation patterns (Elevation 2)

617-960 MHz

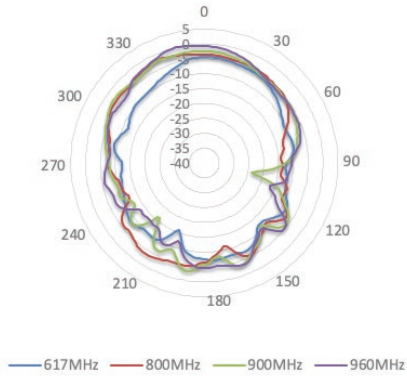

LTE/5G Antenna Radiation patterns (Elevation 2)

3400-3800 MHz

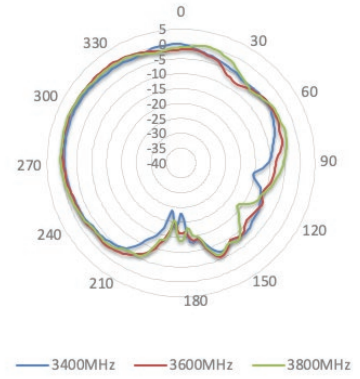

Mobility 22G

1710-2100MHz

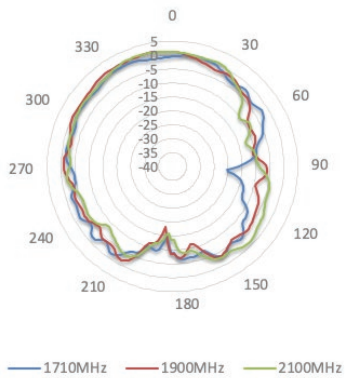

4200-5150 MHz

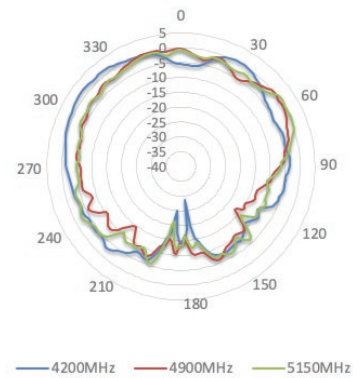

2300-2700 MHz

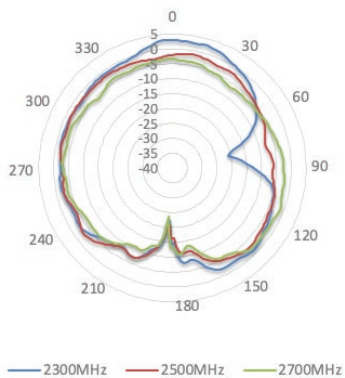

5350-5925 MHz

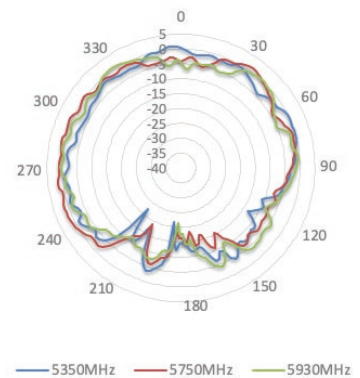

Wi-Fi Antenna Radiation patterns (Elevation 2)

2400-2500 MHz

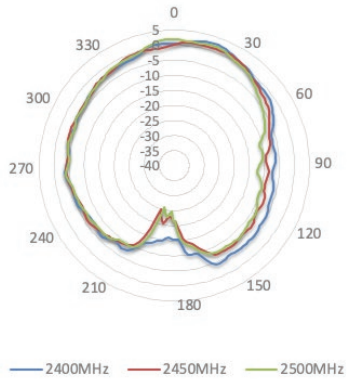

4900-5350 MHz

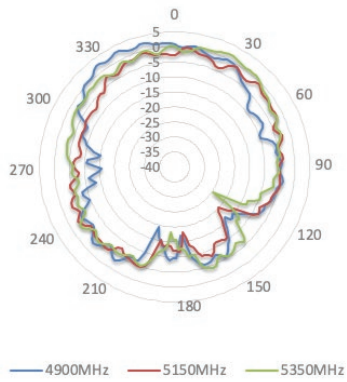

5550-5950 MHz

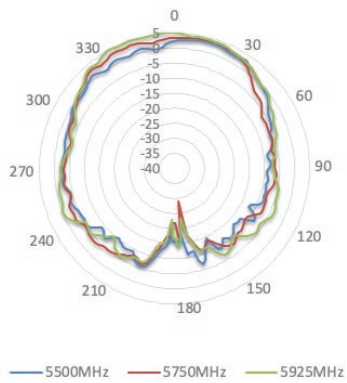

Mobility 22G

Installation recommendation

Panel Mount

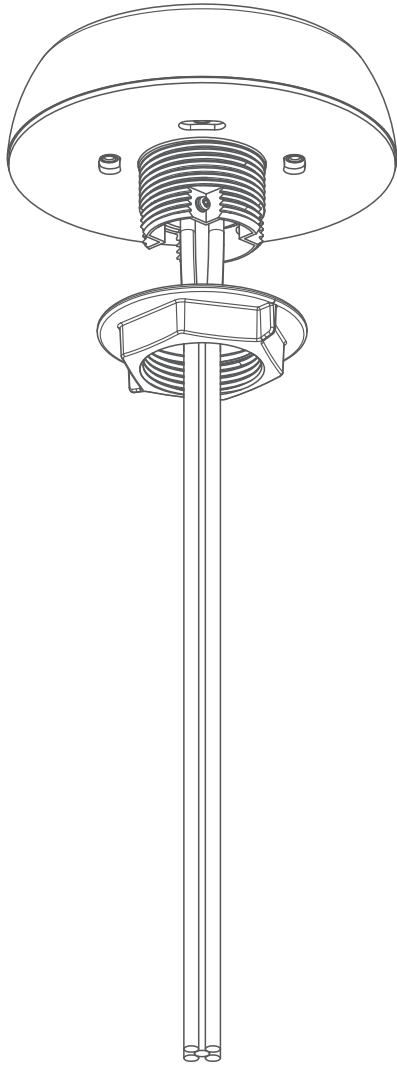

Mobility 22G

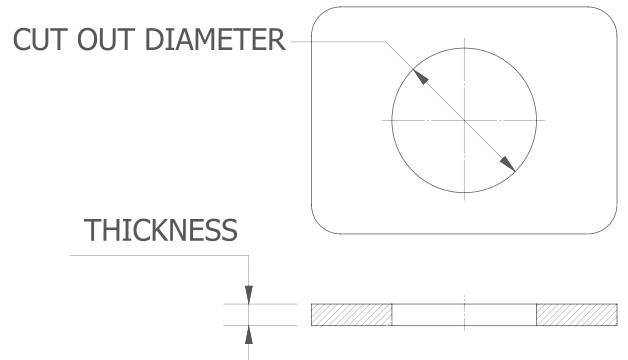

Notes

- Cover panel surface to protect the paint work. When drilling a hole, start with a small one, then increase it.
- Cut out diameter should be 1 11/16" / 43mm.
Maximum allowed panel thickness - 15mm.
- After a drill clean up the surface and apply some paint around the hole to prevent corrosion. Attach the antenna.

Installation recommendation

Pole Mount

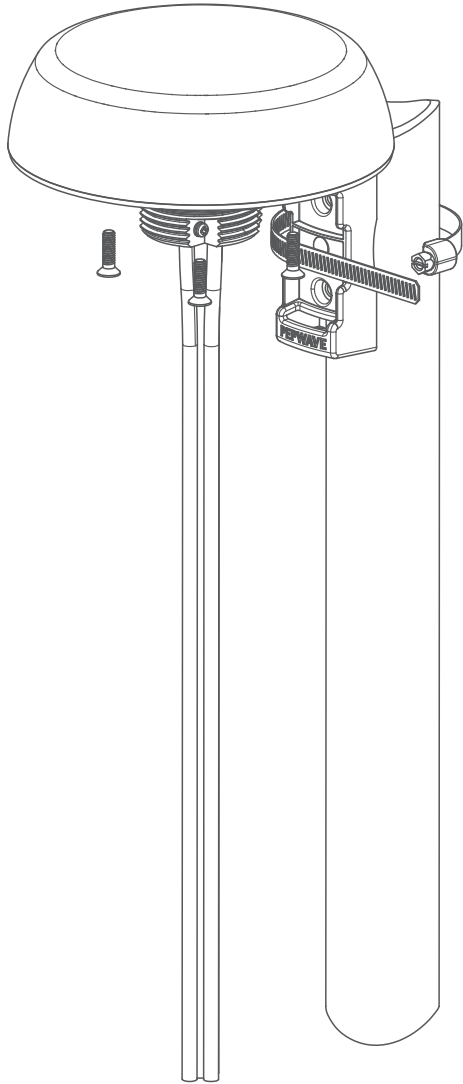

Mobility 22G

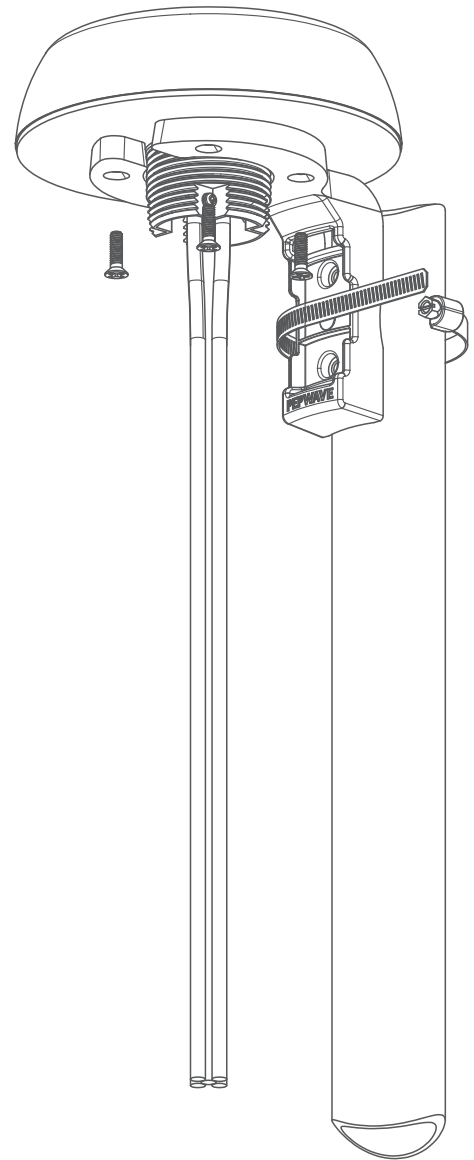

Installation recommendation

Horizontal Pole Mount

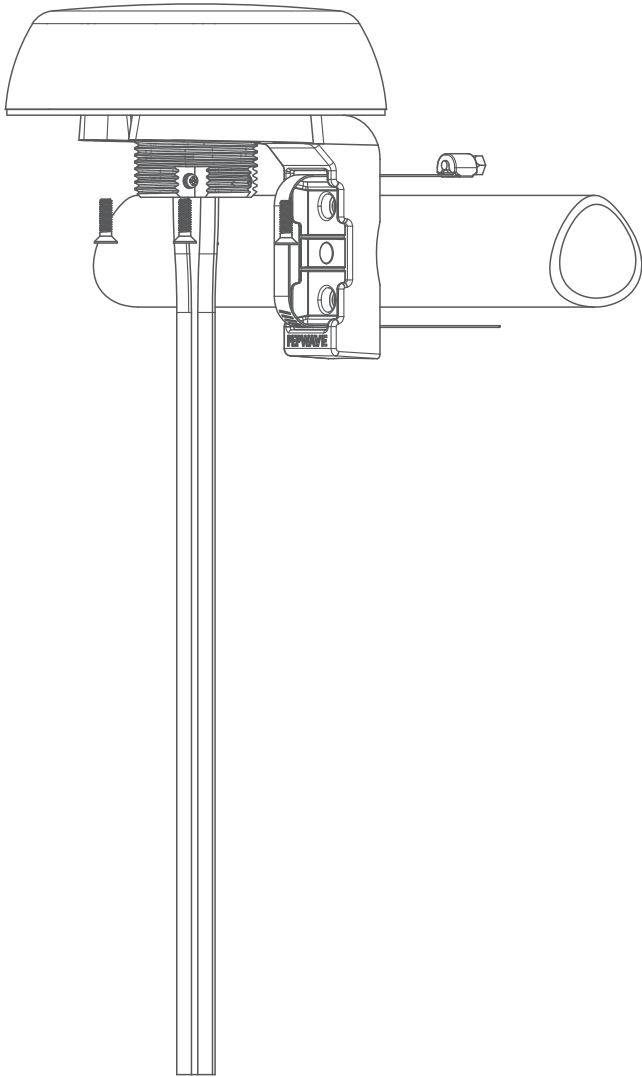

Mobility 22G

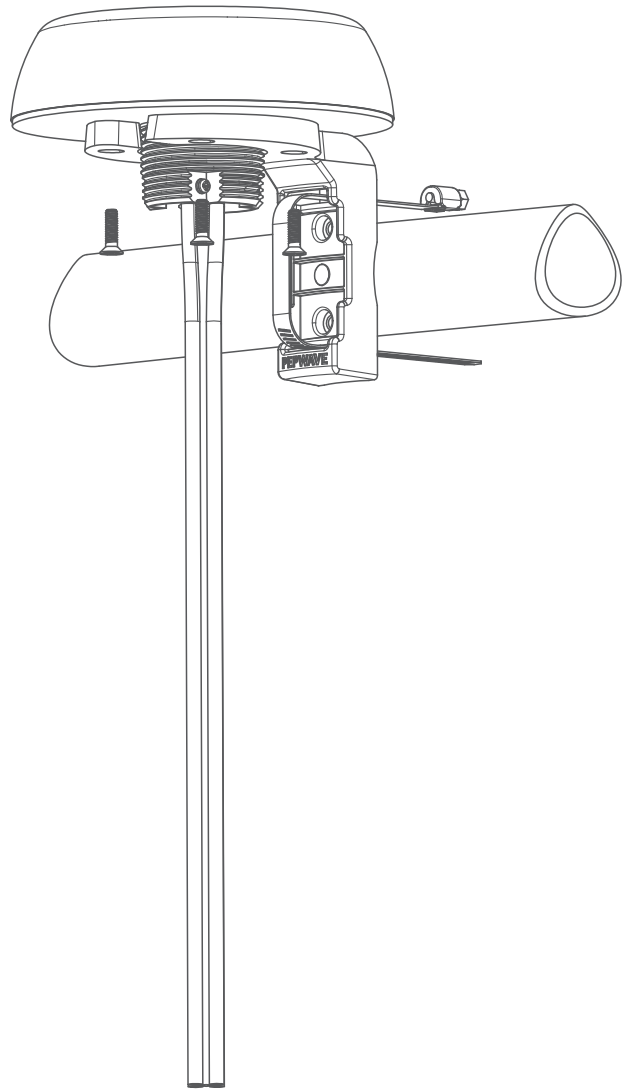

Installation recommendation

Wall Mount

Mobility 22G

