

Unity Gain $\frac{1}{4}$ λ Mobile Antenna for the 450 MHz Band

DESCRIPTION

- Black-chromed stainless steel whip.
- Type MU 1-ZG/s covers 370 – 410 MHz
Type MU 1-ZG/l covers 406 – 440 MHz
Type MU 1-ZG/h covers 430 – 470 MHz
– no tuning required.
- Stainless steel ZG-mount with M8-thread whip-fastening system.
- Simple mounting exclusively with access from the outside.
- Choice between two connection principles:
 - ZG-mount: FME-connection (supplied without cable).
 - ZGP4-mount: Permanently attached 4 m cable terminated with FME-connector.



SPECIFICATIONS

Electrical	
Model	MU 1-ZG/...
Frequency	450 MHz-band covered by three models
Antenna Type	Mobile whip antenna
Max. Input Power	100 W
Polarisation	Vertical
Impedance	50 Ω
VSWR	≤ 1.2 @ f. res.
Bandwidth	≥ 45 MHz @ VSWR ≤ 1.5
Gain (EIA RS-329-1)	0 dB

Mechanical	
Materials	Whip : Stainless steel and brass, black-chromed Mount : Black-chromed brass Weather- and shockproof plastics Stainless steel
Installation Torque	7.5 \pm 1 Nm
Colour	Black
Height	Approx. 180 mm / 7.09 in.
Weight	ZG-version : Approx. 90 g / 0.2 lb. ZGP4-version : Approx. 230 g / 0.51 lb.
Mounting	21 mm dia. hole

ORDERING

Model	Product No.	Description	Frequency
MU 1-ZG/s	130000884	ZG-mount with FME-system	370 - 410 MHz
MU 1-ZG/l	130000886	Same mount as above	406 - 440 MHz
MU 1-ZG/h	130000890	Same mount as above	430 - 470 MHz
MU 1-ZGP4/s	130000887	ZG-mount with 4 m cable and FME-connector	370 - 410 MHz
MU 1-ZGP4/l	130000888	Same mount as above	406 - 440 MHz
MU 1-ZGP4/h	130000889	Same mount as above	430 - 470 MHz

THE WHIP IS COMPATIBLE WITH ALL BELOW MOUNTS



INSTALLATION

This antenna should always be mounted on the car roof to ensure best omnidirectional coverage. The antenna is provided with our type ZG-mount for mounting from the outside in a 21 mm dia. hole.

The ZG-mount is provided with an M8 x 1 thread mount system. This construction meets the demand for a low-profile mobile mount with a slim appearance and with protection against theft of the antenna whip.

When cleaning the car in car-washing machines, the whip is easily removed using a spanner, size 12 mm. The whip is refitted again by screwing it onto the thread stud and tightening it with the spanner.

3. TUNING / MODEL CONVERSION

- The antenna is delivered factory-tuned and requires no further tuning.
- To convert an MU 1-ZG/s model into an MU 1-ZG/l model, cut off 15 mm of the top end of the whip.
- To convert an MU 1-ZG/l model into an MU 1-ZG/h model, cut off 8 mm of the top end of the whip.

2. INSTALLATION STEPS

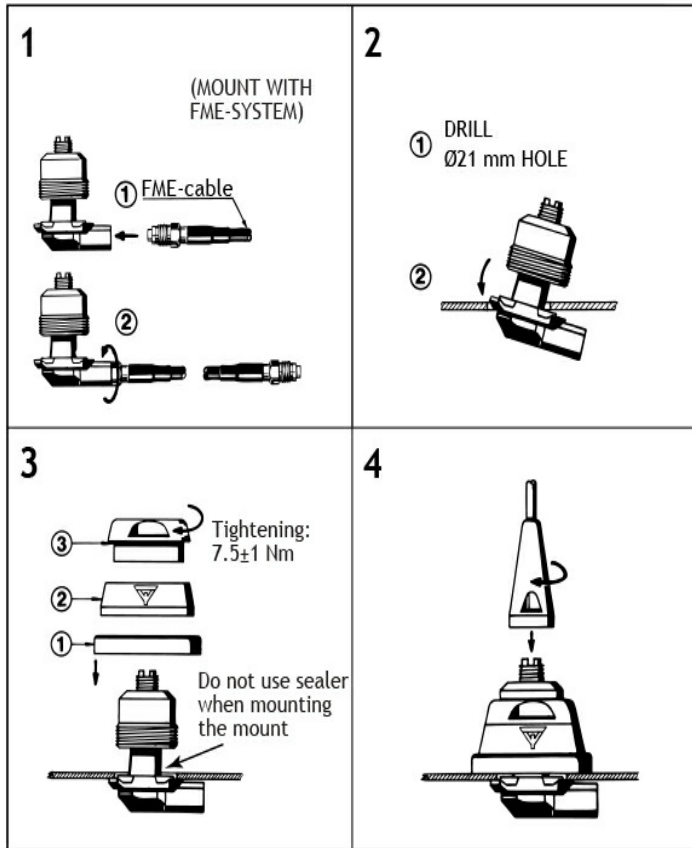

Do not use sealer on rubber gasket or other places.

